

MALIK'S

Single Screw Extruders

We offer highly efficient, high output Plastic Extrusion systems for variety of applications. Chief applications include: • **Layflat film/tubing** • **Rigid PVC pipe/profile** • **Flexile hose pipes from PE/PVC/Nylon** • **Reprocessing, Pelletizing, compounding** • **PVC wires & cables** • **Monofilament & Strapping** • **Thick sheet from ABS/PP/HDPE/PVC/HIPS** • **EPE Foam sheet, Rod, pipe, netting** • **Food processing (for pellet & starch gelatinization..)** • Available screw diameter from 30mm to 100mm.



Layflat tubing units: MEL& MELHM series

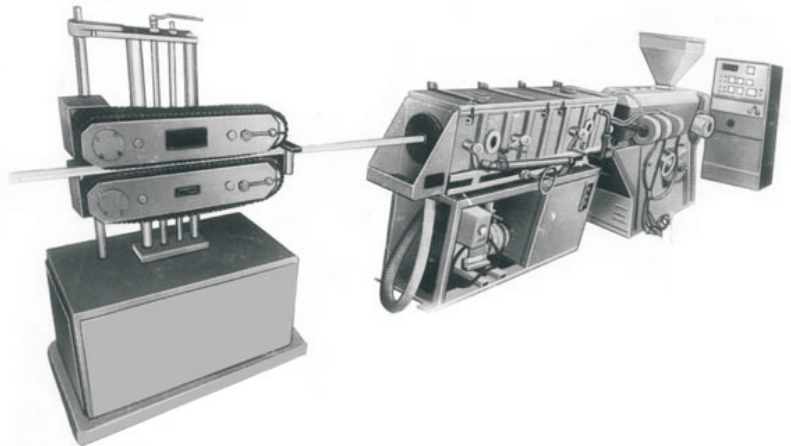

MERP series Rigid/hose pipe Extruders



Reprocessing/Colouring Extruders: MEWR & MEWRV series (Vented & Non-vented)

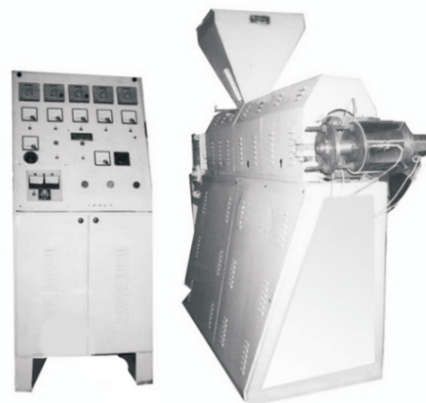

PVC Cable coating Extruders MERWC series

MALIK'S

Foaming Extruders for Polyethylene

Expanded Polyethylene (EPE) sheet, pipe, rod, profile is widely used for producing protection sheet, insulation, expansion joints & for shock mitigation, etc. We have developed Extrusion system for producing such product using Butane gas as blowing agent. Typical product density varies from 0.02g/cc-0.05g/cc (low density foams):

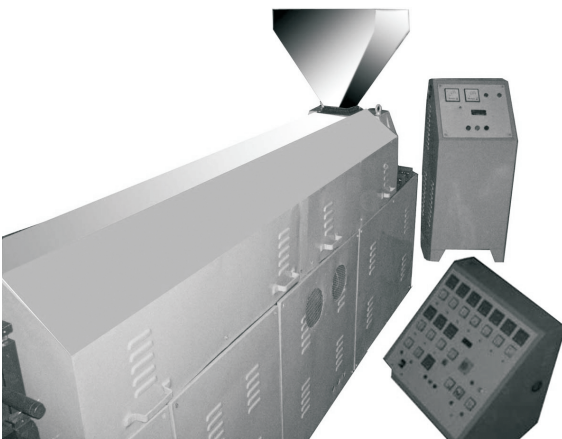
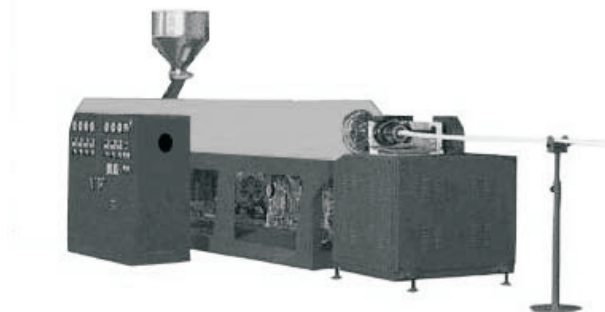
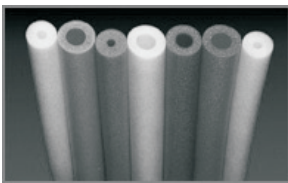
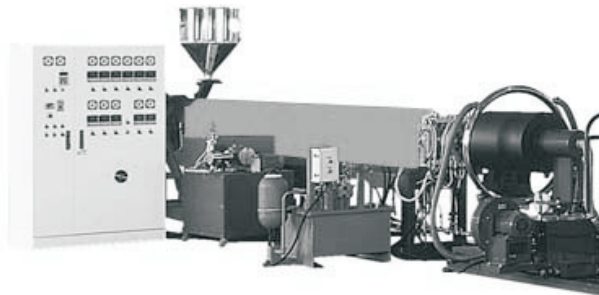

Extruder shown alongside is used for producing EPE liner foam sheet for bottle liners, sport gear, etc. The blowing agent used is Carbon Dioxide gas. Chemically expanded foams use certain chemicals pre-mixed with the resin to provide the gas for expansion of product. Typical product density varies between 0.25-0.5 g/cc. While physical blowing agent (Co₂) is directly injected into the Extruder for low product density.

For further details contact manufacturer:

MALIK ENGINEERS

Fac: Unit-1, Shailesh Ind. Estate-1, Navghar, Vasai Road(East)-401 210, Mah., India, Tel:91-250--2390839
Off: B-203, Atlanta, Evershine Nagar, Malad(west), Mumbai-400 064, India, el: 91-250--28830751